



REVIEW ARTICLE

Potential of Supercritical Solvent Impregnation for Development of Materials with Antibacterial Properties

Irena Zizovic*

Faculty of Chemistry, Wroclaw University of Science and Technology, Poland



*Corresponding author: Irena Zizovic, Faculty of Chemistry, Wroclaw University of Science and Technology, Wybrzeze Wyspianskiego 27, 50-370 Wroclaw, Poland, E-mail: irena.zizovic@pwr.edu.pl; zizovic@tmf.bg.ac.rs

Abstract

Supercritical solvent impregnation is a modern technique which exploits the unique transport properties and qualities of supercritical fluids such as low viscosity, high diffusion coefficients, densities as in a liquid state and zero surface tension, for the fabrication of novel materials. The mentioned properties allow deep penetration of supercritical fluid with a dissolved bioactive substance into a solid matrix enabling even distribution of the active substance through the whole volume of the solid phase which is a unique advantage of this technique and cannot be done using conventional impregnation methods. In this mini-review, literature data on production of materials with antibacterial properties via supercritical solvent impregnation with carbon dioxide will be presented, focusing on textile and polymer materials. Impregnation of non-antibiotic substances, such as natural bioactive components and plant extracts, is discussed. The reviewed data reveals the high and unique potential of supercritical impregnation in the design of new materials with antibacterial properties. Taking into account an urgent need for such materials and the feasibility of supercritical fluid impregnation on industrial scale in textile dyeing and wood impregnation, the application of this technique for antibacterial materials production on industrial scale is expected in the near future.

and dyeing, nano and micro-particle generation, chemical reaction engineering, biomass treatment, chromatography, polymer processing, soil remediation, dry cleaning, crystallization, drying and power generation, whereby a number of patents in these areas is on a constant rise. The advantageous properties of supercritical fluids make them unique and applicable in many areas. The physical properties of supercritical fluids are between the values for a liquid and gas-density similar to liquids, diffusivity and viscosity similar to gases. In addition, those properties are tunable and by varying pressure and temperature fluid of desired characteristics can be applied. Since gas-liquid equilibrium does not exist in a supercritical state, the surface tension of supercritical fluids is zero. This property enables supercritical fluids to easily penetrate a solid matrix and is exploited for extraction and impregnation purposes. The most used supercritical fluid is supercritical Carbon Dioxide (scCO₂) due to its advantageous critical parameters (31.1 °C and 7.38 MPa) which allow processing at low temperatures. Besides, it is inert, non-toxic and low cost. It can be recycled within a process and there is no impact on the environment when using scCO₂ technologies on a larger scale [2].

Introduction

Supercritical fluid is any substance at pressure and temperature above its critical values. At critical point any difference between liquid and gaseous phases disappears, and above it only one phase exists- the supercritical phase. There has been rapid development in the application of supercritical fluids on laboratory scale since the 1970's, as well as on industrial scale since the 1980's- in extraction processes first [1]. Today, supercritical fluid technology is extended to impregnation

Supercritical solvent impregnation

In the Supercritical Solvent Impregnation (SSI) process, supercritical fluid is used as a solvent for the selected bioactive substance, as well as a transport medium to deliver the dissolved bioactive substance into a solid matrix. SSI has numerous advantages over conventional impregnation techniques: Homogeneous distribution of an active component through the whole volume of



Citation: Zizovic I (2017) Potential of Supercritical Solvent Impregnation for Development of Materials with Antibacterial Properties. Int Arch Med Microbiol 1:001.

Received: August 29, 2017; **Accepted:** November 18, 2017; **Published:** November 20, 2017

Copyright: © 2017 Zizovic I. This is an open-access article distributed under the terms of the Creative Commons Attribution License, which permits unrestricted use, distribution, and reproduction in any medium, provided the original author and source are credited.

the solid matrix can be obtained due to the zero surface tension of a supercritical fluid; there is no generation of waste water and no organic solvents used; there is no need for a drying step and energy requirements are considerably lower than those of conventional processes; an excess of active components can be recycled and processing time is shorter. SSI with scCO_2 has been applied on industrial scale in wood impregnation [3-5] and textile dyeing [6-8] providing high quality products and significant reduction of pollution generated by conventional processing in these industries. SSI is environmentally friendly technique with no adverse effects. The main disadvantage of the SSI is high investment cost compared to conventional processes because of high pressures applied (usually in the range from 10 to 30 MPa). However, operative costs are considerably lower due to the absence of the drying step and organic solvents.

SSI has been recognized as a suitable technique in the development of materials with antibacterial properties [9-28]. Due to the great potential of SSI and an urgent need for new materials with antibacterial properties, the author of this article believes that this technique will be applied to their production on industrial scale in the near future. In this mini-review, an overview of literature data on SSI of solid carriers with substances with antibacterial activity will be provided and the potential of this high pressure technique for development of added value materials will be stressed.

Suitable antibacterial agents and carriers

Due to the appearance and spreading of multi-resistant and pan-resistant bacterial strains, science is under constant pressure to find non-antibiotic substances with strong antibacterial activity. It is well known that many plant extracts and purified secondary plant metabolites possess excellent antimicrobial activity. Although studies of the antibacterial properties of plant extracts as well as their components have been present in science for decades, it can be said that this area of science has been relatively neglected for years [29]. However, due to the catastrophic consequences of antibiotic

resistance over the past ten years, studies of the antimicrobial activity of plant extracts have intensified and become a hit in science [29]. The ability of plant extracts to enhance antibiotics against resistant strains has been reported as well [30]. A few examples of plant extracts obtained by supercritical fluid extraction, with strong antibacterial activity against broad spectra of bacteria including resistant strains are: lichen extracts [15, 19, 29, 31-33], hops (*Humulus lupulus*) extract [29, 34], oregano, thyme, rosemary and sage extracts [35, 36]. Some of the secondary plant metabolites derived from these extracts and proven to be strong antibacterials are usnic acid [37], thymol [38] and carvacrol [39]. Named scCO_2 soluble extracts and substances are also shown to be valuable active principles in the fabrication of materials with antibacterial properties using SSI.

Depending on the target application, an appropriate solid carrier to be impregnated with an antibacterial agent should be selected. Different polymer and textile materials are of interest for application in hospitals as medicinal textile, wound dressings, catheters and medical devices, tapes for the protection of frequently touched places etc. In the production of implants, biodegradable polymers are most often demanded. Prior to the SSI process optimization, it is mandatory to investigate the behavior of the selected carrier when exposed to pure scCO_2 , as well as in the presence of the active compound. Swelling of polymers due to CO_2 sorption offers the possibility of tailoring the physical properties of the final product (e.g. desired pore size distribution, foaming) as well. Additionally, the selected active component may also have a plasticizing effect on polymer. Thus, unique new materials such as scaffolds for cell tissue engineering and systems for controlled drug delivery can be fabricated using scCO_2 technology.

SSI mechanism is usually complex and depends on processing conditions (pressure and temperature), interactions between the polymer and scCO_2 as well as between the polymer and the active component, and finally the rate of decompression. The active component can be simply entrapped into the polymer matrix due to decompression when CO_2 undergoes fast transition

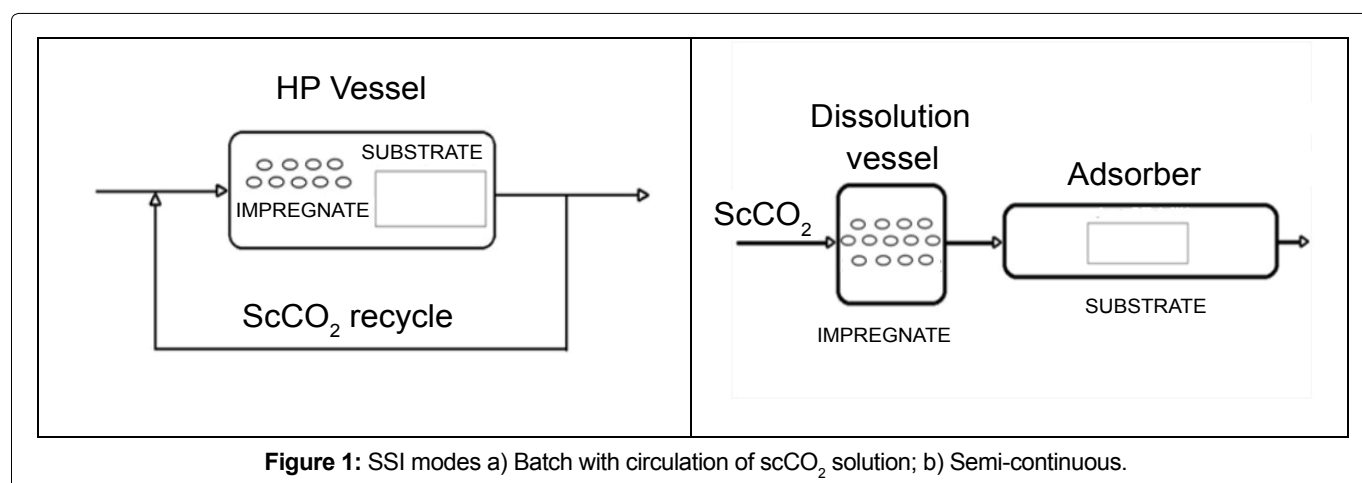

Figure 1: SSI modes a) Batch with circulation of scCO_2 solution; b) Semi-continuous.

extract into polyester textile. The impregnated textile inhibited growth of *Escherichia coli*.

Impregnation of polymers: In recent years, research on the development of antimicrobial active surfaces for polymer parts with the aim of developing materials for prevention of infectious agents transmission has become increasingly important [14,41]. Especially the contact transmission via contaminated objects such as doorknobs, switches and handrails is the principal route of exposure of pathogens [14,42]. Besides the already mentioned medicinal textile, wound dressings and catheters, in the medical field, antimicrobial active substances are used in orthopedic implants, prostheses, vascular grafts, heart valves, catheter coatings, wound dressings, ointments, surgical instruments etc [14,43].

High pressure carbon dioxide (liquid and supercritical) assisted impregnation of polycarbonate surfaces with silver nitrate as an antibacterial agent was investigated by Mölders, et al. [14]. All impregnated samples using compressed carbon dioxide were initially antimicrobial active as they devitalized more than 99.8% of the bacteria *Escherichia coli*. Abrasion as well as UV-radiation led to a loss of antimicrobial activity of the samples impregnated with liquid carbon dioxide. In contrast to that, the samples obtained with scCO₂ resisted abrasion as well as UV-radiation tests and kept their antibacterial properties [14].

Polymer indicated to be a promising carrier of active substances in the development of materials with antibacterial properties via SSI is Cellulose Acetate (CA) [9-11]. It was shown that high loadings of thymol and carvacrol in CA were possible to obtain due to the establishment of hydrogen bonds between the hydroxyl group of thymol/carvacrol and the polymer. High loadings of these antibacterials into CA- up to 72% and 63% for thymol and carvacrol, respectively [9-11] enable fabrication of CA based materials with antibacterial properties against a wide spectrum of bacteria and antifungal properties against *Candida albicans*, for different applications and with different release times of the active component up to 21 days [9-11]. Impregnated samples showed excellent antimicrobial activity against *Staphylococcus aureus* including Methicillin-Resistant *Staphylococcus aureus* (MRSA) strains, *Escherichia coli*, *Candida albicans*, *Acinetobacter* sp., *Bacillus anthracis*, *Bacillus cereus*, *Bacillus subtilis*, *Corynebacterium* sp., *Klebsiella pneumoniae*, and *Salmonella enteritidis* [9,11]. Our recent results [44] have revealed that it is possible to fabricate thymol-loaded CA films which completely prevent cell adhesion and biofilm formation in *Staphylococcus aureus* and *Pseudomonas aeruginosa* including resistant strains.

Starch and chitosan are biodegradable polymers of interest in biomedical applications. These polymers in the form of aero or xero-gels, as well as films/composite films are suitable for SSI with active components. Milo-

vanovic, et al. [28] investigated SSI of chitosan aero and xero-gels with thymol, whereby thymol loadings of up to 11.3% were obtained. Milovanovic, et al. [21] also investigated the influence of corn and tapioca starch xero- and aero-gels preparation method on thymol loadings by SSI and reported thymol contents of up to 4%. De Svoza, et al. [25] investigated SSI of cinnamaldehyde into cassava starch biocomposite films for the development of food active packaging. Results showed that all tested SSI conditions permitted to impregnate antimicrobial active amounts superior to those previously obtained using conventional incorporation methods. Moreover, a significant decrease in the equilibrium water vapor sorption capacity and water vapor permeability of the films was observed after SSI processing which is also an advantage of the process [25].

Poly(lactic Acid (PLA) is a polymer suitable for scCO₂ processing. This polymer may undergo foaming when exposed to scCO₂. Therefore, in a one-step high pressure process it is possible to obtain PLA foam with loaded antibacterial substance such as thymol [45]. It was shown that a sufficiently high amount of thymol can be loaded into both PLA monolith and film using SSI after only 2 h (10.0% and 6.6%, respectively). Villegas, et al. [26] investigated SSI of cinnamaldehyde into PLA as a route to developing antibacterial food packaging materials, whereby impregnation yields ranging from 8 to 13% were obtained. Impregnated films were more flexible, less brittle and more resistant materials than neat PLA films. The tested samples showed strong antibacterial activity against *Escherichia coli* and *Staphylococcus aureus*. Torres, et al. [24] investigated the effect of processing conditions on the physical, chemical and transport properties of PLA films containing thymol incorporated by SSI. Depending on the impregnation process conditions, thymol was incorporated into the films at concentrations from 13.5 to 20.5% and consequently SSI of PLA with thymol was identified as a promising technique in preparing active biodegradable materials for a wide range of applications [24].

Low Density Polyethylene (LDPE) is suitable for the fabrication of polymer films for different applications. Torres, et al. [27] investigated near critical and supercritical impregnation and kinetic release of thymol in linear LDPE films used for food packaging, whereby thymol loadings of up to 3.8% were obtained. In another study [23] LDPE nanocomposites prepared with different concentrations of an organo-modified montmorillonite were impregnated with thymol using scCO₂, with the aim of obtaining an antimicrobial packaging, whereby the highest obtained incorporation percentage of thymol was 1.19%.

The potential of a batch SSI for processing of Polycaprolactone (PCL) and Polycaprolactone-Hydroxyapatite (PCL-HA) composites for obtaining functional thymol-impregnated porous scaffolds with antibacterial prop-

erties was studied by Ivanovic, et al. [18]. Moderately high pressures (13-17 MPa) and 10% of HA were proven to be favorable for the creation of PCL based scaffolds with satisfying foam microstructure (mean pore size ~ 200-300 µm), filler distribution and thymol impregnation yields (12-18%) [18].

The Integrated process of supercritical fluid extraction and adsorption was developed by Fanovic, et al. [15] with the aim of creating a process for the production of functionalized PCL scaffolds impregnated with natural compounds with antibacterial activity extracted from Patagonian Usnea lichen. In order to establish optimized operating conditions, supercritical extraction as well as sorption kinetics and resulting material properties have been studied separately first. Useful scaffolds of PCL for tissue engineering containing a porous structure with pore diameters from 150 to 340 µm and extract loading of up to 2.8% were obtained in this process. Antibacterial activity of fabricated scaffolds was confirmed against *Listeria innocua* and MRSA. The integrated process was also successfully applied in the impregnation of corn starch xero-gel, PCL and polypropylene textile material with hop extract [46] as well as cotton gauze, CA, polypropylene textile material, corn starch xero-gel, PCL and chitosan xero-gel with thyme extract [16].

Conclusion

Supercritical solvent impregnation is an environmentally friendly technique which offers the possibility of even distribution of an active substance through the whole volume of a carrier appropriate for the envisaged application. This process excludes usage of organic solvents and liquid effluents generation, requires shorter processing times and has lower energy demands compared to conventional processes. According to the results of studies reviewed in this article, SSI is a promising technique for the fabrication of novel materials with antibacterial properties against broad spectra of bacteria, as well as antifungal properties against *Candida albicans*. Since there is an increased demand for new materials that provide reduction in microbial spreading, there is space for the application of SSI on industrial scale for this purpose. Textile materials can be finished using SSI for application as medicinal textiles or as primary or secondary wound dressings. Polymers for different purposes, from medicinal devices to surfaces that prevent bacteria's adhesion and transmission, can be modified to acquire antibacterial properties. Due to the sorption of scCO₂ into polymers, it is also possible to tailor polymers properties in order to obtain a new morphology, e.g. desired pore size distribution. In case of using supercritical extract, as an active component, an integrated process of supercritical fluid extraction and impregnation is suggested.

References

1. M McHugh, V Krukonic (1994) Supercritical Fluid Extraction. (2nd edn), Butterworth-Heinemann, Stoneham, USA.
2. G Brunner (2005) Supercritical fluids: technology and application to food processing. *Journal of Food Engineering* 67: 21-33.
3. AW Kjellow, O Henriksen (2009) Supercritical wood impregnation. *The Journal of Supercritical Fluids* 50: 297-304.
4. J Fernandes, AW Kjellow, O Henriksen (2012) Modeling and optimization of the supercritical wood impregnation process-Focus on pressure and temperature. *The Journal of Supercritical Fluids* 66: 307-314.
5. Qader, L Cookson (2001) Treatment of eucalypt heartwood using supercritical carbon dioxide as a Carrier. 27th Products Research Conference, CSIRO Forestry and Forest Products, Clayton, Australia Proceedings 6-7.
6. M van der Kraan, MVF Cid, GF Woerlee, WJT Veugelers, GJ Witkamp (2007) Dyeing of natural and synthetic textiles in supercritical carbon dioxide with disperse reactive dyes. *The Journal of Supercritical Fluids* 40: 470-476.
7. SK Liao, PS Chang (2012) Literatures on dyeing technique of supercritical fluid carbon dioxide. *American Journal of Analytical Chemistry* 3: 923-930.
8. <http://www.dyecoo.com/>
9. S Milovanovic, M Stamenic, D Markovic, J Ivanovic, I Zizovic (2015) Supercritical impregnation of cellulose acetate with thymol. *The Journal of Supercritical Fluids* 97: 107-115.
10. S Milovanovic, D Markovic, K Aksentijevic, DB Stojanovic, I Zizovic, et al. (2016) Application of cellulose acetate for controlled release of thymol. *Carbohydr Polym* 147: 344-353.
11. S Milovanovic, T Adamovic, K Aksentijevic, D Mistic, J Ivanovic, et al. (2017) Cellulose acetate based material with antibacterial properties created by supercritical solvent impregnation. *International Journal of Polymer Science* 2017: 8762649.
12. Y Chen, P Yu, C Feng, Y Wang, Q Han, et al. (2017) Synthesis of polysiloxane with quaternized N-halamine moieties for antibacterial coating of polypropylene via supercritical impregnation technique. *Applied Surface Science* 419: 683-691.
13. J Sanchez Sanchez, MT Fernández Ponce, L Casas, C Mantell, EJM de la Ossa (2017) Impregnation of mango leaf extract into a polyester textile using supercritical carbon dioxide. *The Journal of Supercritical Fluids* 128: 208-217.
14. N Mölders, M Renner, C Errenst, E Weidner (2017) Incorporation of antibacterial active additives inside polycarbonate surfaces by using compressed carbon dioxide as transport aid. *The Journal of Supercritical Fluids*.
15. MA Fanovich, J Ivanovic, D Mistic, MV Alvarez, I Zizovic, et al. (2013) Development of polycaprolactone scaffold with antibacterial activity by an integrated supercritical extraction and impregnation process. *The Journal of Supercritical Fluids* 78: 42-53.
16. J Ivanovic, S Milovanovic, M Stamenic, MA Fanovich, I Zizovic, et al. (2014) Application of an integrated supercritical extraction and impregnation process for incorporation of thyme extracts into different carriers. In: Jane Osborne, *Handbook on Supercritical Fluids: Fundamentals, Properties and Applications*. Nova Science Publishers, New York, 257-281.
17. S Milovanovic, M Radetic, D Mistic, J Asanin, I Zizovic, et al. (2017) High pressure modified cotton in wound dressing applications. In: Stuart Gordon, Nouredine Abidi, *Cotton Fibers: Characteristics, Uses and Performance*. Nova Science Publishers, New York, 177-206.
18. J Ivanović, S Knauer, A Fanovich, S Milovanovic, M Sta-

- menic, et al. (2016) Supercritical CO₂ sorption kinetics and thymol impregnation of PCL and PCL-HA. *The Journal of Supercritical Fluids* 107: 486-498.
19. MA Fanovich, J Ivanovic, I Zizovic, D Mistic, P Jaeger (2016) Functionalization of polycaprolactone/hydroxyapatite scaffolds with *Usnea lethariiformis* extract by using supercritical CO₂. *Mater Sci Eng C Mater Biol Appl* 58: 204-212.
 20. D Markovic, S Milovanovic, M Radetic, B Jokic, I Zizovic (2015) Impregnation of corona modified polypropylene non-woven material with thymol in supercritical carbon dioxide for antimicrobial application. *Journal of Supercritical Fluids* 101: 215-221.
 21. S Milovanovic, I Jankovic Castvan, J Ivanovic, I Zizovic (2014) Effect of starch xero- and aerogels preparation on the supercritical CO₂ impregnation of thymol. *Starch-Stärke* 66: 1-9.
 22. S Milovanovic, M Stamenic, D Markovic, M Radetic, I Zizovic (2013) Solubility of thymol in supercritical carbon dioxide and its impregnation on cotton gauze. *The Journal of Supercritical Fluids* 84: 173-181.
 23. A Rojas, A Torres, F Martínez, L Salazar, C Villegas, et al. (2017) Assessment of kinetic release of thymol from LDPE nanocomposites obtained by supercritical impregnation: Effect of depressurization rate and nanoclay content. *European Polymer Journal* 93: 294-306.
 24. A Torres, E Ilabaca, A Rojas, F Rodríguez, MJ Galotto, et al. (2017) Effect of processing conditions on the physical, chemical and transport properties of polylactic acid films containing thymol incorporated by supercritical impregnation. *European Polymer Journal* 89: 195-210.
 25. AC de Souza, AMA Dias, HC Sousa, CC Tadini (2014) Impregnation of cinnamaldehyde into cassava starch biocomposite films using supercritical fluid technology for the development of food active packaging. *Carbohydr Polym* 102: 830-837.
 26. C Villegas, A Torres, M Riosa, A Rojas, J Romero, et al. (2017) Supercritical impregnation of cinnamaldehyde into polylactic acid as a route to develop antibacterial food packaging materials. *Food Res Int* 99: 650-659.
 27. A Torres, J Romero, A Macan, A Guarda, MJ Galotto (2014) Near critical and supercritical impregnation and kinetic release of thymol in LLDPE films used for food packaging. *The Journal of Supercritical Fluids* 85: 41-48.
 28. S Milovanović, M Pantić, J Ivanović, I Žižović (2015) Influence of the chitosan gel preparation method on its supercritical impregnation with thymol. *Tehnika* 3: 391-396.
 29. Mišić (2014) The applicability of supercritical extracts in clinical treatment of bacterial infections in humans and animals, in *Supercritical CO₂ extraction and its applications*. Edward Rój, Polish Foundations of the Opportunities Industrialization Centers "OIC Poland", Lublin, Poland, 57-98.
 30. R Chovanová, M Mikulášová, Š Vaverková (2013) In Vitro Antibacterial and Antibiotic Resistance Modifying Effect of Bioactive Plant Extracts on Methicillin-Resistant *Staphylococcus epidermidis*. *International Journal of Microbiology* 2013: 760969.
 31. I Zizovic, J Ivanovic, D Mistic, M Stamenic, S Djordjevic, et al. (2012) SFE as a superior technique for isolation of extracts with strong antibacterial activities from lichen *Usnea barbata* L. *The Journal of Supercritical Fluids* 72: 7-14.
 32. S Weckesser, K Engel, B Simon Haarhaus, A Wittmer, K Pelz, et al. (2007) Screening of plant extracts for antimicrobial activity against bacteria and yeasts with dermatological relevance. *Phytomedicine* 14: 508-516.
 33. J Ivanovic, F Meyer, D Mistic, J Asanin, P Jaeger, et al. (2013) Influence of different pre-treatment methods on isolation of extracts with strong antibacterial activity from lichen *Usnea barbata* using carbon dioxide as a solvent. *The Journal of Supercritical Fluids* 76: 1-9.
 34. E Rój, VM Tadić, D Mišić, I Zizovic, I Arsić, et al. (2015) Supercritical carbon dioxide hops extracts with antimicrobial properties. *Open Chem* 13: 1157-1171.
 35. M Stamenic, J Vulic, S Djilas, D Mistic, V Tadic, et al. (2014) Free-radical scavenging activity and antibacterial impact of Greek oregano isolates obtained by SFE. *Food Chem* 165: 307-315.
 36. J Ivanovic, D Mistic, I Zizovic, M Ristic (2012) In vitro control of multiplication of some food-associated bacteria by thyme, rosemary and sage isolates. *Food Control* 25: 110-116.
 37. K Ingólfssdóttir (2002) Molecules of interest: Usnic acid. *Phytochemistry* 61: 729-736.
 38. P Tippayatum, V Chonhenchob (2007) Antibacterial activities of thymol, eugenol and nisin against some food spoilage bacteria. *Kasetsart J (Nat Sci)* 41: 319-323.
 39. AB Arfa, S Combes, L Preziosi Belloy, N Gontard, P Chalier (2006) Antimicrobial activity of carvacrol related to its chemical structure. *Lett Appl Microbiol* 43: 149-154.
 40. G Borkow, J Gabbay (2008) Biocidal textiles can help fight nosocomial infections. *Med Hypotheses* 70: 990-994.
 41. DR Monteiro, LF Gorup, AS Takamiya, AC Ruvollo Filho, ER de Camargo, et al. (2009) The growing importance of materials that prevent microbial adhesion: Antimicrobial effect of medical devices containing silver. *Int J Antimicrob Agents* 34: 103-110.
 42. CP Gerba, AH Tamini, S Carlino, S Edmonds (2014) Impact of an alcohol-based hand sanitizer intervention on the spread of viruses in homes. *Food Environ Virol* 6: 140-144.
 43. JM Lagaron, MJ Ocio, A Lopez Rubio (2012) *Antimicrobial Polymers*. (1st edn), Wiley.
 44. I Zizovic, L Senerovic, I Moric, T Adamovic, M Jovanovic, et al. Utilization of supercritical carbon dioxide in fabrication of cellulose acetate based films with anti-biofilm effects against *Pseudomonas aeruginosa* and *Staphylococcus aureus*. Submitted to the *Journal of CO₂ Utilization*.
 45. SL Milovanović, RM Kuska, MLJ Lučić Škorić, MT Kalagasidis Krušić, S Frerich, et al. (2016) Swelling Kinetics and Impregnation of PLA with Thymol under Supercritical CO₂ Conditions. *Tehnika* 25: 16-20.
 46. I Zizovic, J Ivanovic, S Milovanovic, M Stamenic (2014) Impregnations using supercritical carbon dioxide in *Supercritical CO₂ extraction and its applications*. Edward Rój, Polish Foundations of the Opportunities Industrialization Centers "OIC Poland", Lublin, Poland, 23-34.